

# Hårnåle / U-bolte



Hårnåle / U-bolte til runde rør  
Fås sorte, varmgalvaniseret og  
rustfri AISI 304L og AISI 316L



U-bolts for round pipes  
Black, hot-dip galvanized and stainless  
AISI 304L and AISI 316L

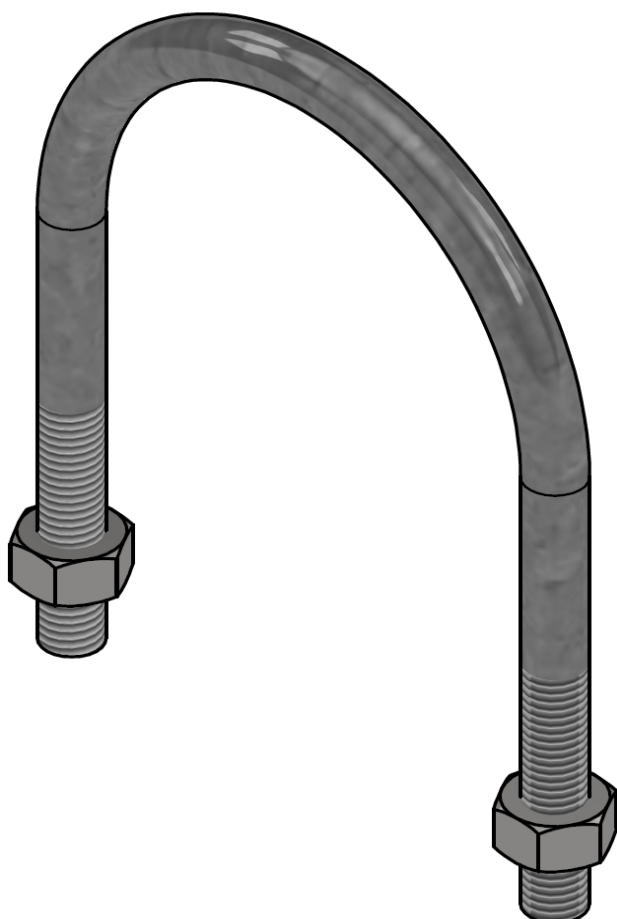
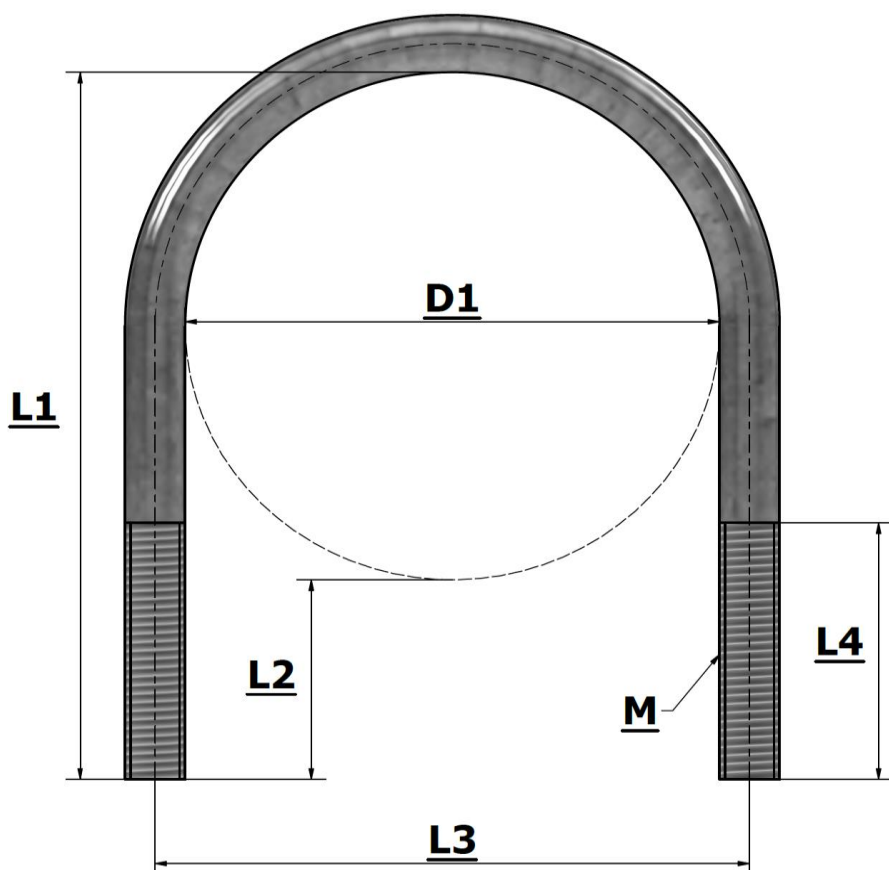

Str. / Size	Rørdiameter / Pipediameter	DN str. / DN size	Tomme str. / Inch size	Gevind / Thread	L1	L2	L3	L4
D1 (mm)	(mm)	(mm)	(tommer)	M (mm)	(mm)	(mm)	(mm)	(mm)
60	60,3	50	2	M16	110	50	76	65
64	63,5			M16	114	50	80	65
67	67			M16	117	50	83	65
70	70			M16	120	50	86	65
73	73			M16	123	50	89	65
76	76,1	65	2 1/2	M16	126	50	92	65
80	80			M16	130	50	96	65
84	84			M16	134	50	100	65
89	88,9	80	3	M16	139	50	105	65
97	97			M16	147	50	113	65
101	101,6	90	3 1/2	M16	151	50	117	65
104	104			M16	154	50	120	65
108	108	90		M16	158	50	124	65
110	110			M16	160	50	126	65
114	114,3	100	4	M16	164	50	130	65
120	120			M16	170	50	136	65
122	122			M16	172	50	138	65
129	129			M16	179	50	145	65
133	133,1	100		M16	183	50	149	65
140	139,7	125	5	M16	190	50	156	65
146	146			M16	196	50	162	65
154	154			M16	204	50	170	65
159	159	125		M16	209	50	175	65
168	168,3	150	6	M16	218	50	184	65
178	177,8			M16	228	50	194	65
194	193,7	175	7	M16	244	50	210	65
200	200			M16	250	50	216	65
220	219,1	200	8	M16	270	50	236	65
225	225			M16	275	50	241	65
245	244,5	200		M16	295	50	261	65
250	250			M16	300	50	266	65
267	267	200		M16	317	50	283	65
273	273	250	10	M16	323	50	289	65
300	300			M16	350	50	316	65
318	318			M16	368	50	334	65
324	323,9	300	12	M16	374	50	340	65
356	355,6	350	14	M16	406	50	372	65
368	368	350		M16	418	50	384	65
406	406,4	400	16	M16	456	50	422	65
419	419	400	16 1/2	M16	469	50	435	65
457	457,2	450	18	M16	507	50	473	65
470	470			M16	520	50	486	65
508	508	500	20	M16	558	50	524	65
521	521			M16	571	50	537	65
610	610	600	24	M16	660	50	626	65
711	711,2	700	28	M16	761	50	727	65
813	813	800	32	M16	863	50	829	65

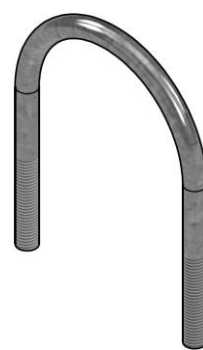

Sort  
Black

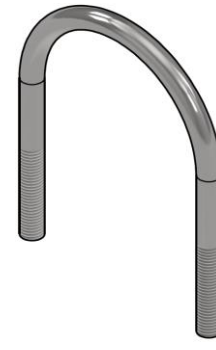

Varmgalvaniseret  
Hot-dip galvanized

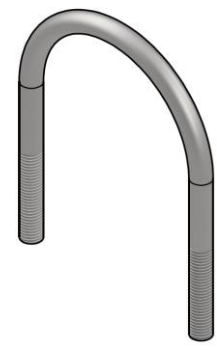

Rustfri AISI 304L/316L  
Stainless AISI 304L/316L